

SLB Bulkhead Jack Receptacles

Straight Jacks

Straight Male Bulkhead Jack Receptacle

- Solder pot contact
- Rear mount

3004-1511-000 (Gold plated)
3004-7511-000 (Nickel plated)

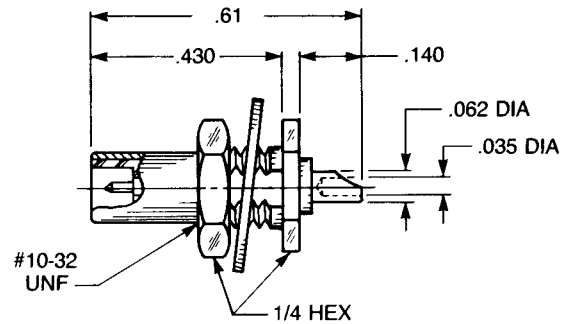

Straight Male Bulkhead Jack Receptacle

- Solder pot contact
- Front mount

3019-1511-000 (Gold plated)
3019-7511-000 (Nickel plated)

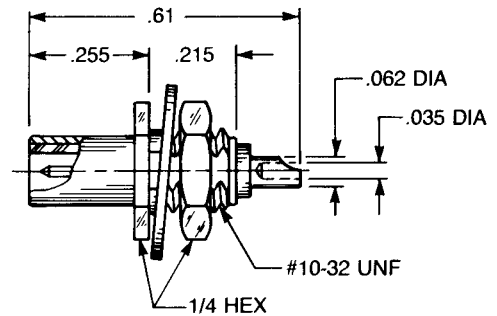

Straight Male Bulkhead Jack Receptacle

- Solder pot contact
- Recessed front mount

3014-1511-000 (Gold plated)
3014-7511-000 (Nickel plated)

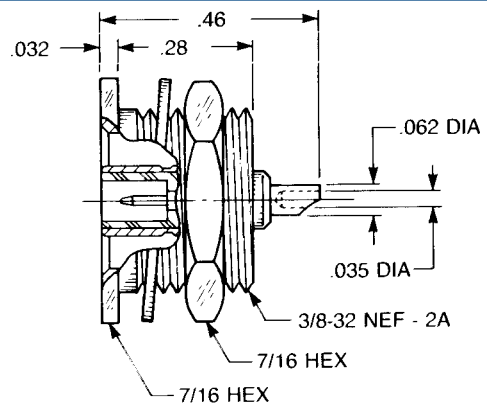

Right Angle Jacks

Right Angle Male Bulkhead Jack Receptacle

- Solder pot contact
- Front mount

3012-1511-000 (Gold plated)
3012-7511-000 (Nickel plated)

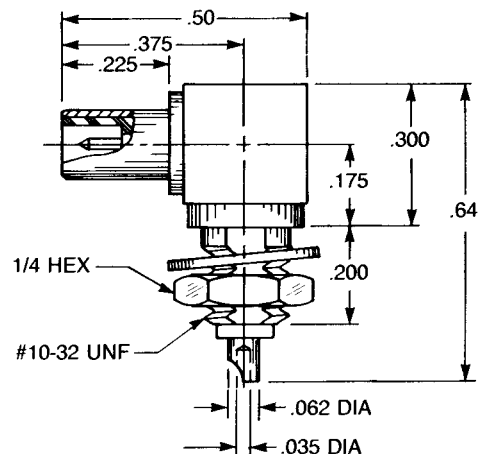

(All fit .093" max panel thickness)



APPLIED ENGINEERING PRODUCTS

(203) 776-2813 • FAX (203) 776-8294

www.aepconnectors.com • aepsales@aepconnectors.com

SLB Bulkhead Plug Receptacles

Straight Plugs

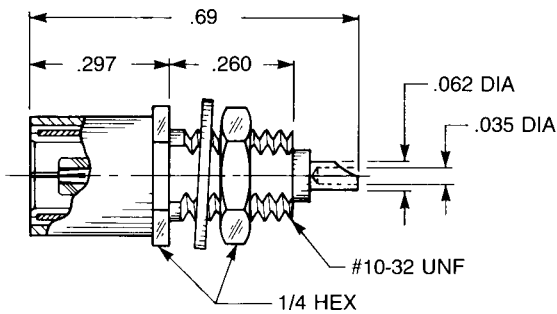

Straight Female Bulkhead Plug Receptacle

- Solder pot contact
- Front mount

3017-1511-000 (Gold plated)
3017-7511-000 (Nickel plated)

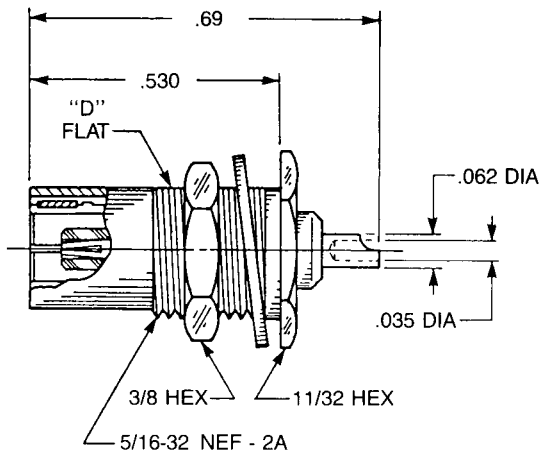

Straight Female Bulkhead Plug Receptacle

- Solder pot contact
- Rear mount

3048-1511-000 (Gold plated)
3048-7511-000 (Nickel plated)

Right Angle Plugs

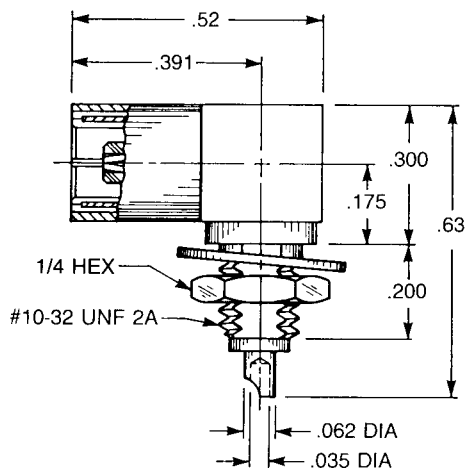

Right Angle Female Bulkhead Plug Receptacle

- Solder pot contact
- Front mount

3097-1511-000 (Gold plated)
3097-7511-000 (Nickel plated)

(All fit .093" max panel thickness)



APPLIED ENGINEERING PRODUCTS

(203) 776-2813 • FAX (203) 776-8294

www.aepconnectors.com • aepsales@aepconnectors.com

Mounting Dimensions

Bulkhead Receptacles

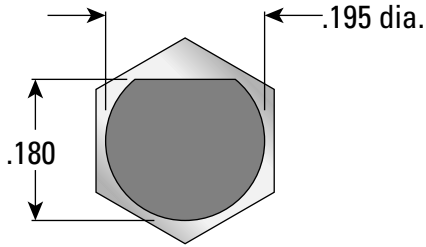

Flat of mounting surface is aligned with body hex as shown.

P.C. Board Receptacles

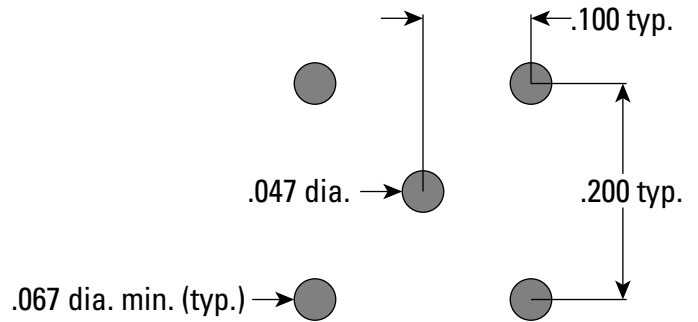

Assembly Tooling

Crimp tool

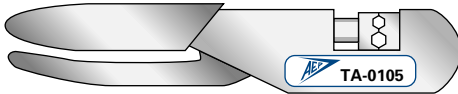

DESCRIPTION	AEP P/N
Crimp tool with .105" and .128" hex dies	TA-0105

Torque Wrench

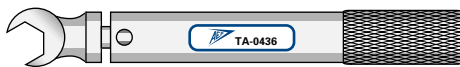

DESCRIPTION	AEP P/N
Torque wrench with 7/32" jaws for SLB connector backnuts; 95 inch-ounces torque	TA-0436

Capping Press

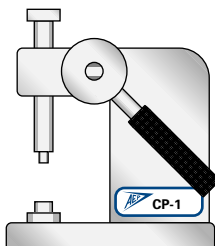

DESCRIPTION	AEP P/N
Capping tool (arbor press) with base for SLB right angle plugs	CP-1
Capping tool (arbor press) with base for SLB right angle jacks	CP-6